

REV	DESCRIPTION	DATE	BY
A	NEW DRAWING	05/06/13	JAG

SKT3927

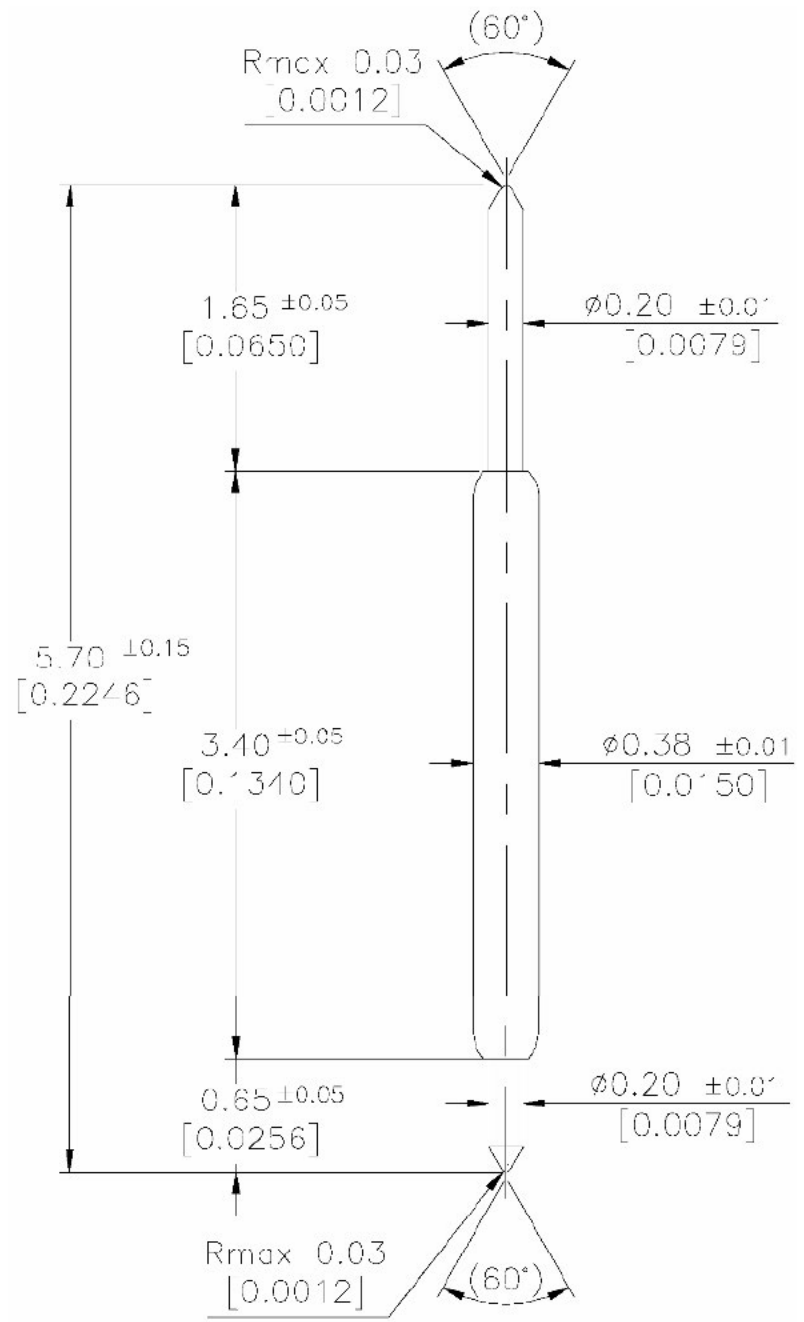

Pointing Accuracy: ± 0.085 mm

Spring Force: ± 20%

STATE	TRAVEL	SPRING FORCE
Initial Travel	--	7.6 g (0.268 oz)
*Recommended Travel	0.75 mm (0.0295)	21.0 g (0.741 oz)
*Full Travel	0.80 mm (0.0315)	21.6 g (0.762 oz)

*NOTE: It is very important to verify the actual working travel when this probe is set in a socket due to difference of only 0.05mm between recommended and full travel. In case that the actual working travel is over 0.75mm, the device, spring and/or plunger will be damaged.

PART	MATERIAL	FINISH
Plunger (Top)	Hardened Beryllium Copper	Gold Plated
Plunger (Bottom)	Hardened Beryllium Copper	Gold Plated
Barrel	Phosphor Bronze	Gold Plated
Spring	Stainless Steel	Gold Plated

DIMENSIONS ARE IN MM UNLESS OTHERWISE SPECIFIED
 TOLERANCES ARE:
 X.X ±0.100MM ANGULAR:
 X.XX ±0.050MM X.X° ±1.0°
 X.XXX ±0.025MM X.XX° ±0.5°

ALL DIMENSIONS ARE IN MILLIMETERS UNLESS OTHERWISE SPECIFIED

		EMULATION TECHNOLOGY, INC. VLSI and SMT ADAPTERS and ACCESSORIES	
		759 FLYNN ROAD CAMARILLO, CA 93012	
TEL: (805) 383-8480 FAX: (805) 383-8484		ASSEMBLY DRAWING	
SHEET: 1 OF 1	DATE: 05/06/13	REVISION: A	ITEM: POGO-PIN-5.70-D
CHECKED:	PREPARED BY: J. GELACIO		
DO NOT SCALE DRAWING			DESCRIPTION: POGO-PIN-5.70-D