

REV	DESCRIPTION	DATE	BY
A	NEW DRAWING	11/22/10	JAG

SKT3556

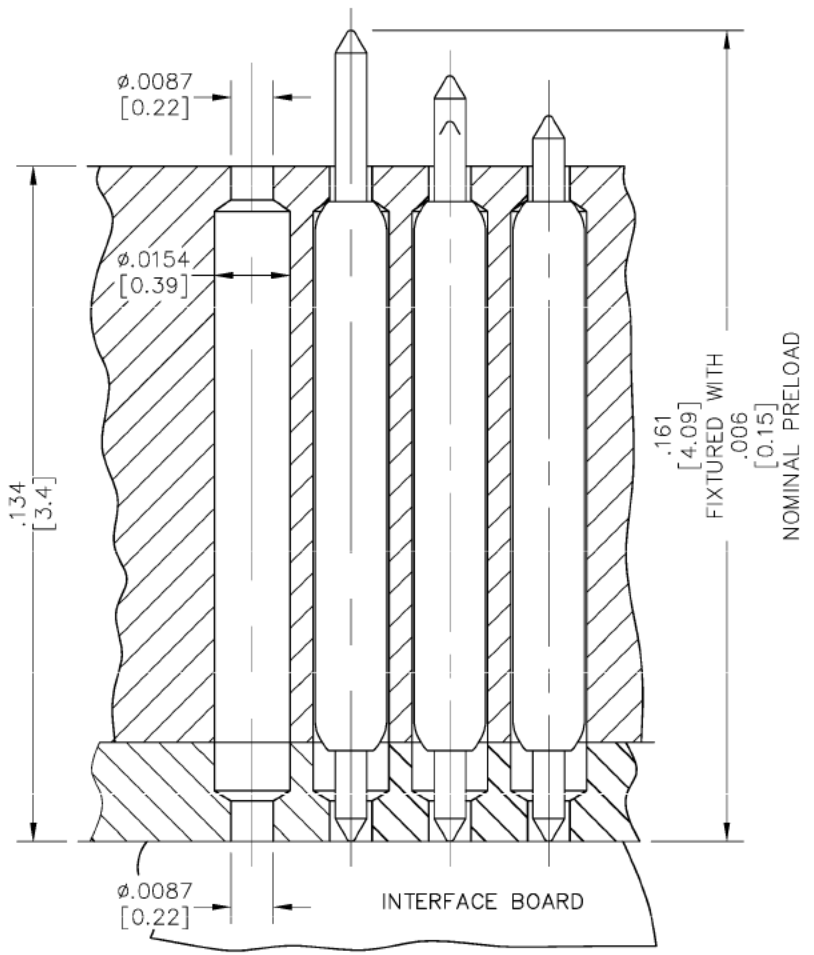
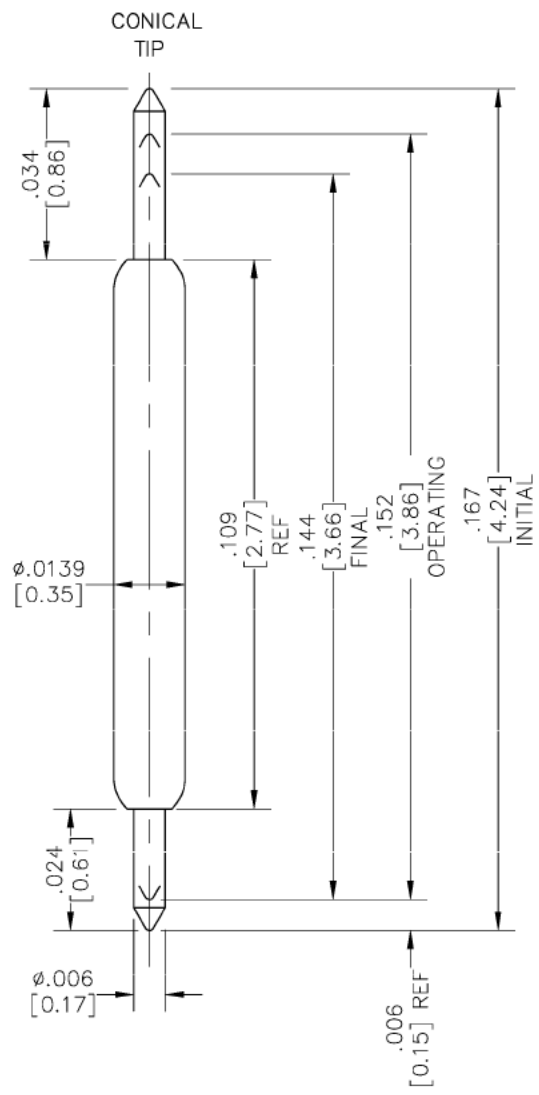

NOTES

- 1 FORCE
 14g (0.5oz) initial
 21g (0.8oz) fixed
 32g (1.1oz) at op
- 2 FIXED MOUNTING DIMENSIONS SHOWN FOR REFERENCE

UNLESS OTHERWISE SPECIFIED DIMENSIONS ARE IN MILLIMETERS
 TOLERANCES:
 DECIMALS ANGLES
 X \pm 0.1 \pm 1°
 XX \pm 0.05
 XXX \pm 0.030

Item No.	Components	Material	QTY	Surface
1	Conical tip plunger	Hardened BeCu	1	Gold plated
2	Barrel	Copper alloy	1	Gold plated
3	Conical tip plunger	Hardened steel	1	Palladium-plated
4	Spring	Music wire	1	Gold plated

ALL DIMENSIONS ARE IN MILLIMETERS UNLESS OTHERWISE SPECIFIED

		EMULATION TECHNOLOGY, INC. VLSI and SMT ADAPTERS and ACCESSORIES	
		759 FLYNN ROAD CAMARILLO, CA 93012	TEL: (805) 383-8480 FAX: (805) 383-8484
SHEET: 1 OF 1	DATE: 11/22/10	REVISION: A	ASSEMBLY DRAWING
CHECKED:	PREPARED BY: J. GELACIO	ITEM: POGO-PIN-4.24-1	
DO NOT SCALE DRAWING			DESCRIPTION: POGO-PIN-4.24-1