

REV	DESCRIPTION	DATE	BY
A	NEW DRAWING	08/30/10	JAG

SKT3506

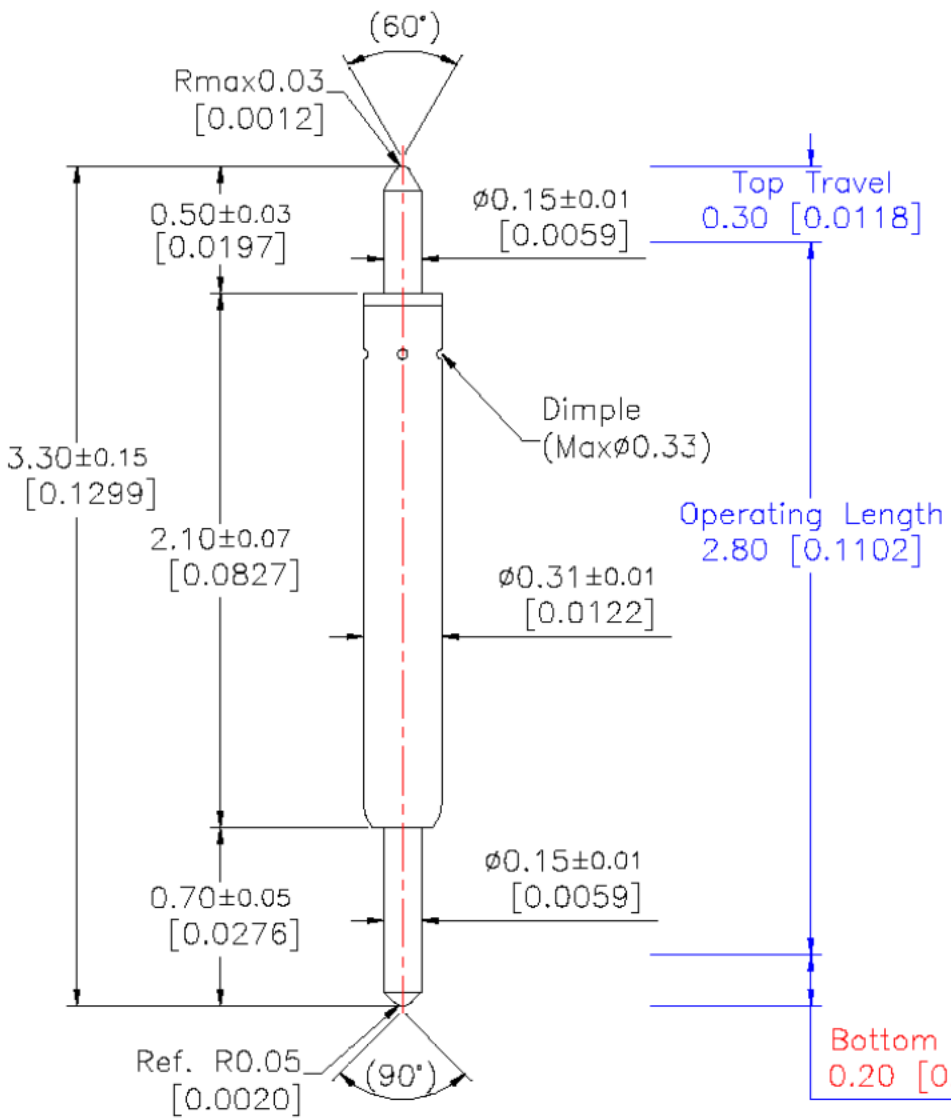

It is very important to verify the actual working travel when this probe is set in a socket due to difference of only 0.10mm between recommended and full travel. In case that the actual working travel is over 0.50mm, the device, spring, plunger and/or PCB pad will be damaged. Therefore, the above notice must be reflected in socket design.

- Pointing accuracy : ± 0.08 mm
- Spring force [±20%]
 - 5.0g(0.176oz) at initial travel
 - 25.1g(0.885oz) at 0.50mm(0.0197) recommended travel
 - 29.1g(1.026oz) at 0.60mm(0.0236) full travel
- Material & Finish

Terminal (Top)	Hardened Carbon Steel	/ Gold Plated
Plunger (Bottom)	Hardened Beryllium copper	/ Gold Plated
Barrel	Ni-Au Alloy	/ Gold Plated
Spring	Music Wire	/ Gold Plated

*** Notice :**
0.20mm or more of Preload
 at bottom side is **MUST** in use for durability of the pin when the pin is set in DUT Board.

ALL DIMENSIONS ARE IN MILLIMETERS UNLESS OTHERWISE SPECIFIED			
		EMULATION TECHNOLOGY, INC. — VLSI and SMT ADAPTERS and ACCESSORIES —	
		759 FLYNN ROAD CAMARILLO, CA 93012	TEL: (805) 383-8480 FAX: (805) 383-8484
SHEET: 1 OF 1	DATE: 08/30/10	REVISION: A	ASSEMBLY DRAWING
CHECKED:	PREPARED BY: J. GELACIO		ITEM: POGO-PIN-3.30-2
DO NOT SCALE DRAWING			DESCRIPTION: POGO-PIN-3.30-2