

REV	DESCRIPTION	DATE	BY
A	NEW DRAWING	07/30/07	H.N.

SKT2966

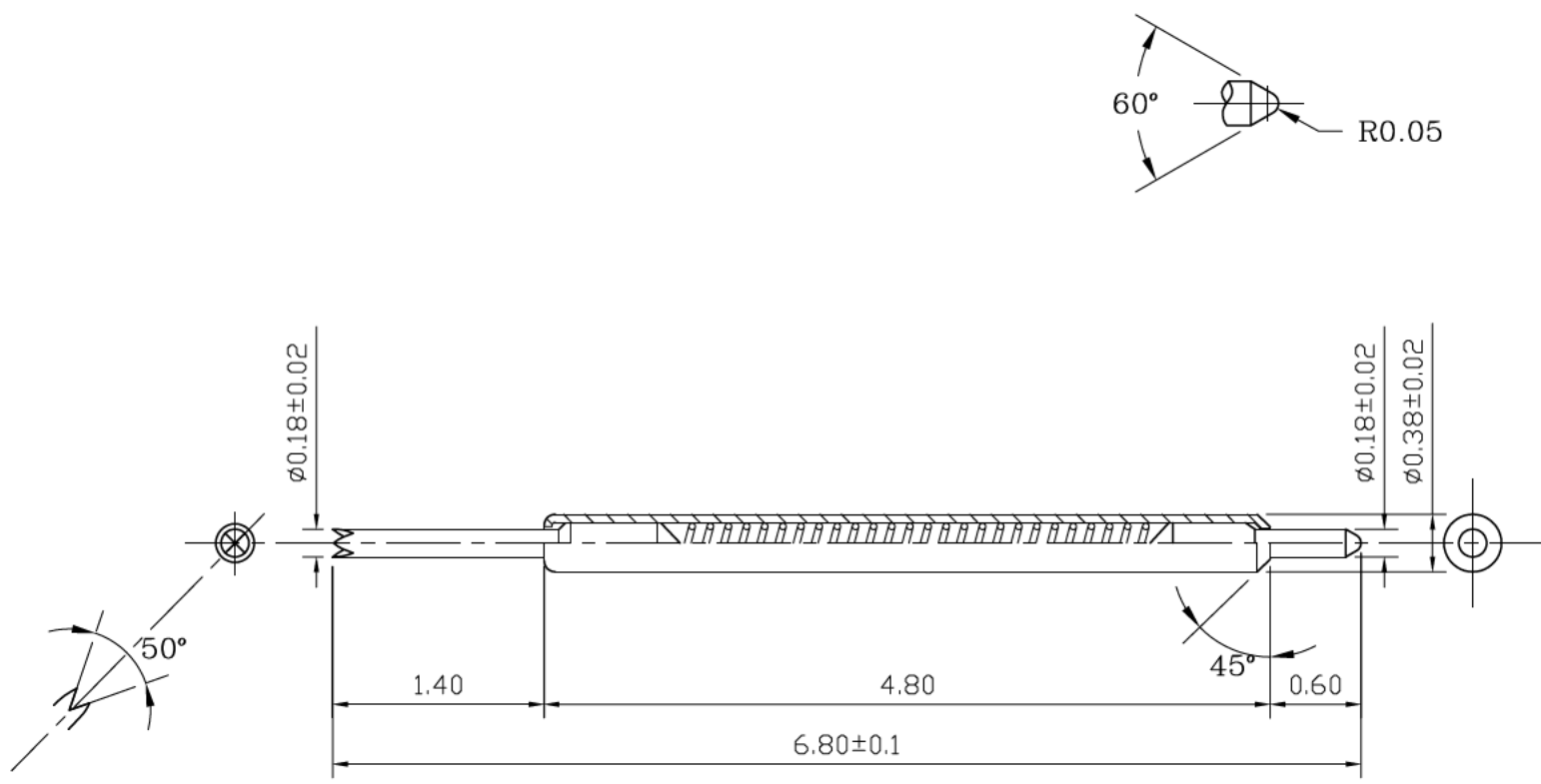

NOTES:
 THE Max. RECOMMENDED TRAVEL IS 1.0mm AT WHICH PIN THE SPRING FORCE IS 30g.
 THE STANDARD TRAVEL IS 0.5mm ON TOP PLUNGER AND THE FORCE AT THAT POINT IS 18g.



Emulation Technology, Inc.
 — VLSI and SMT ADAPTERS and ACCESSORIES —

2344 Walsh Avenue, Bldg.F
 Santa Clara, Ca 95051
 TEL:(408)982-0660
 FAX:(408)982-0664

DIMENSIONS ARE IN MILLIMETERS	
TOLERANCES:	
DECIMALS	ANGLES
X ±0.1	±1°
XX ±0.05	
XXX ±0.030	

SHEET: 1 OF 1	DATE: 07/30/07	REVISION: A	ASSEMBLY DRAWING
CHECKED:	DRAWN: H.N.	ITEM: POGO-PIN-6.80-1	
Scale N/A	DO NOT SCALE DRAWING		DESCRIPTION: POGO-PIN-6.80-1